

## **INSPECT TUB FOR DAMAGE**

WARRANTY REQUIRES TUB TO BE INSPECTED FOR DAMAGE BEFORE INSTALLATION IS BEGUN. CONTACT THE DEALER WHERE YOU PURCHASED THE TUB IF A PROBLEM EXISTS.

## **CHECK FOR LEAKS**

PLACE TUB ON A FLAT SURFACE OUTSIDE IN YARD OR DRIVEWAY AND FILL WITH WATER 1" ABOVE HIGHEST JET. TURN PUMP ON AND CHECK FOR LEAKS AND EACH JET FOR FLOW.

## **FRAMING AND INSTALLATION INSTRUCTIONS**

### **STEP ONE**

PLACE TUB ON FLAT LEVEL SURFACE AND MEASURE FROM THE BOTTOM LIP OF TUB TO FLOOR AT LOCATIONS INDICATED IN THE ILLUSTRATIONS BELOW.

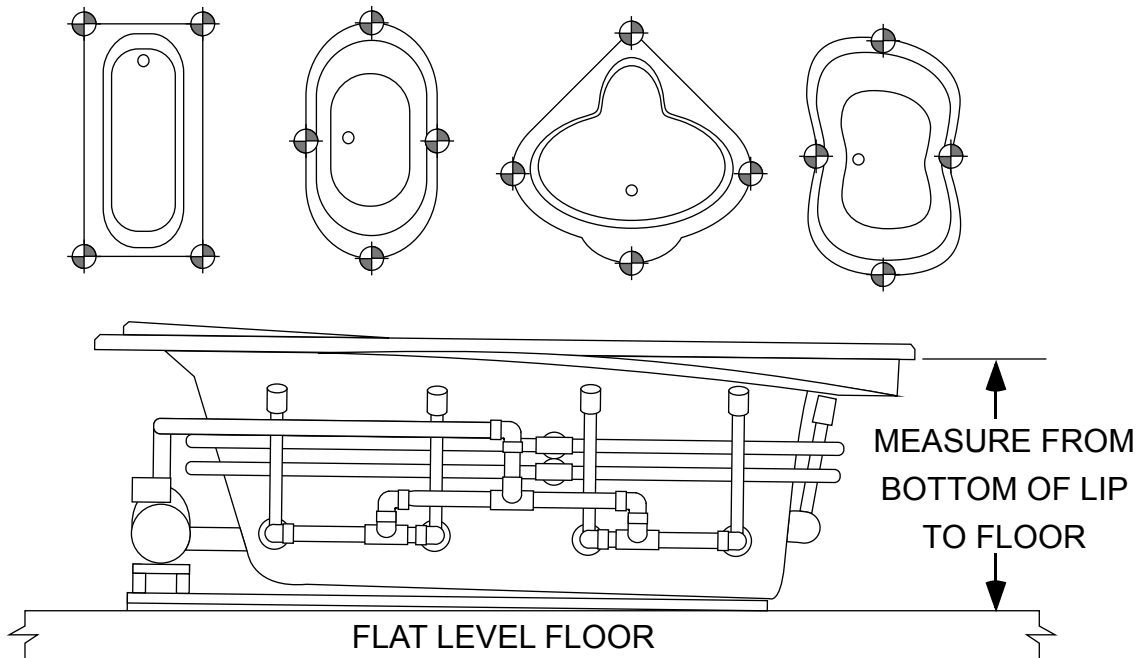

### **STEP TWO**

ADD 1/2" TO THE LARGEST MEASUREMENT TAKEN.

### **STEP THREE**

CONSTRUCT THE CABINET THAT THE TUB WILL SIT IN USING THE DIMENSION FROM STEP TWO. CABINET TOP MUST BE LEVEL IN ALL DIRECTIONS AND CABINET DEPTH MEASURED FROM FINISHED MATERIAL (USUALLY TILE) TO THE FLOOR.

TUB LIP MUST BE SUPPORTED ALL AROUND

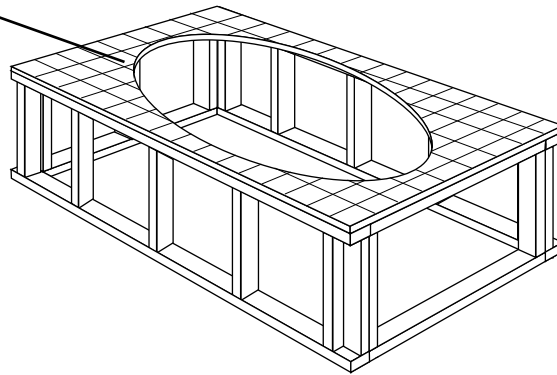

### **STEP FOUR**

PLACE TUB INTO CABINET.

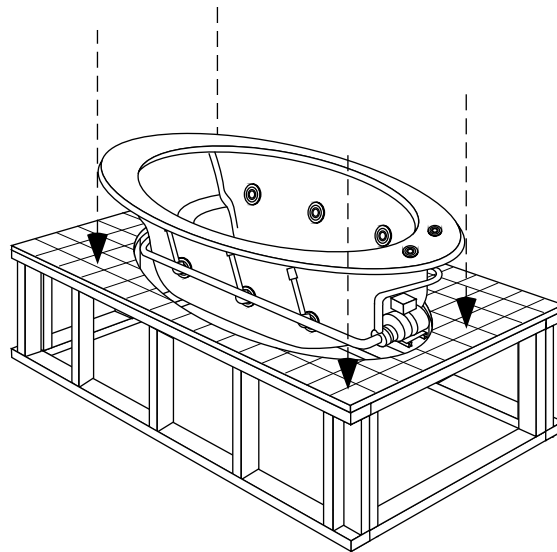

## **STEP FIVE**

LOOK AT AREA UNDER TUB. THE STEEL RAILS SHOULD BE APPROXIMATELY 1/2" OFF FLOOR. THE SPACE BETWEEN THE TUB BOTTOM AND THE FLOOR MUST BE FILLED WITH MORTAR IN THE NEXT STEP.

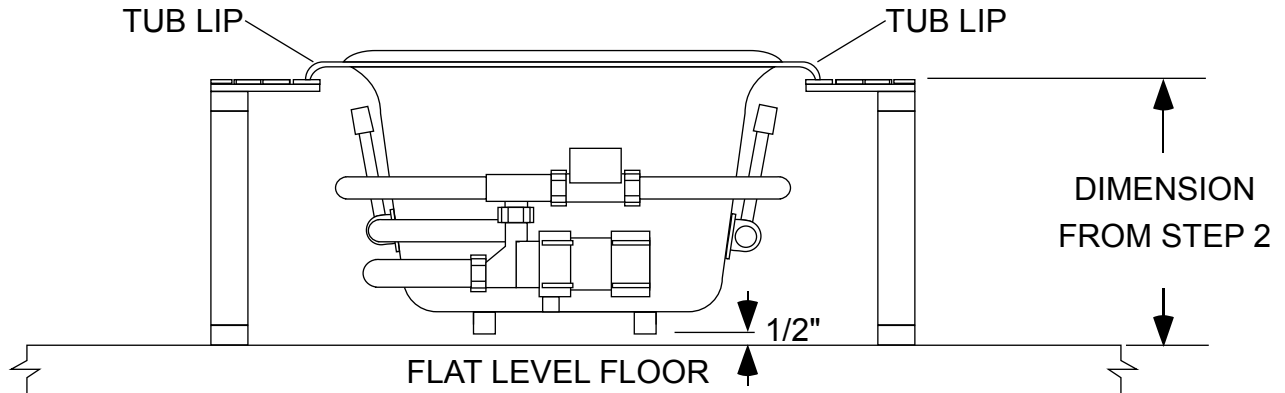

## **STEP SIX**

TAKE TUB OUT OF CABINET AND PLACE ENOUGH MORTAR ONTO FLOOR IN THE AREA UNDER THE TUB BOTTOM TO COMPLETELY FILL THE SPACE YOU SAW IN STEP FIVE. THIS IS USUALLY 2" TO 4".

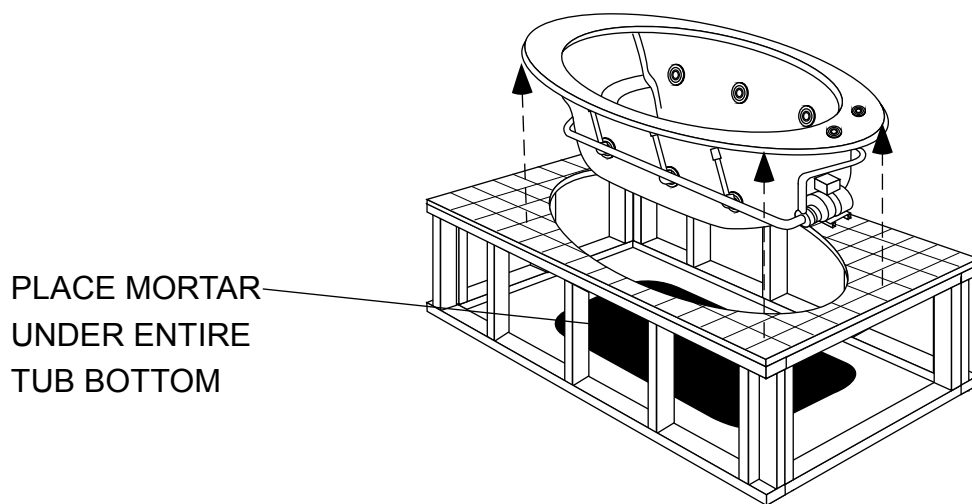

## **STEP SEVEN**

PLACE THE TUB BACK INTO CABINET AND PUSH DOWNWARD UNTIL TUB LIP RESTS EVENLY ON TOP OF THE CABINET, THE AREA BETWEEN THE TUB BOTTOM AND THE FLOOR IS FILLED COMPLETELY, AND THE MORTAR SQUISHES OUT AROUND TUB'S BOTTOM.

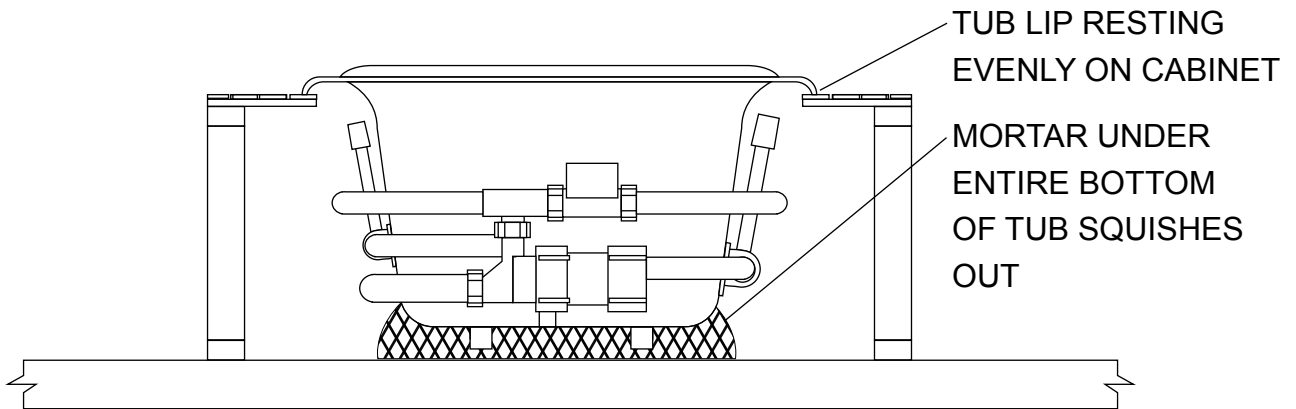

WARRANTY REQUIRES THE ENTIRE AREA UNDER TUB'S BOTTOM TO BE COMPLETELY FILLED WITH MORTAR. ALLOW MORTAR TO HARDEN COMPLETELY BEFORE ANY WEIGHT IS PLACED IN TUB'S BOTTOM.

NOTE: TUB'S WEIGHT (INCLUDING BATHER AND WATER) MUST BE SUPPORTED BY MORTAR UNDER THE TUB'S BOTTOM - NOT THE TUB LIP THAT RESTS ON THE CABINET TILE.

**QUESTIONS? PLEASE CALL: 1800-289-8827 FOR ASSISTANCE**